

BAEK PTZ 26x

1/4 " SONY Super HAD CCD HI-Speed Dome Camera

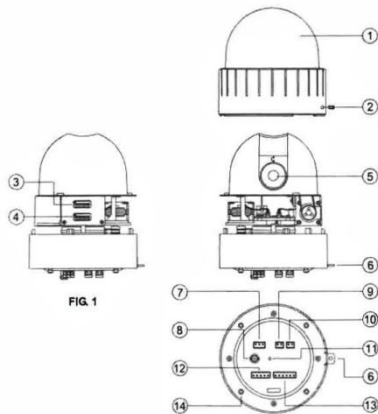

- | | |
|-----------------|------------------|
| 1. Bubble | 8. Video Output |
| 2. Lock Screw | 9. Loop RX |
| 3. DIP Switch 1 | 10. Loop TX |
| 4. DIP Switch 2 | 11. Power LED |
| 5. Camera | 12. Aux |
| 6. Lock Holder | 13. Alarm |
| 7. Power | 14. Mount Holder |



Baek Enterprise Ltd. Important Features

- 26x Optical Zoom, 10x Digital Zoom, Total Zoom 270x.
- 6.6-inch Bubble: Poly-Carbonate, Vandal proof.
- 360° Endless (Pan), Vertical - 92° (Tilt)
- Max Speed: Pan - 360°/sec, Tilt speed: 200°/sec (On Preset mode)
- WDR(On / Off / Auto)
- Day & Night of Mechanical Filter change (0.1Lux)
- Sensitive up to 0.003Lux
- 64 Camera Angle Preset Positions
- Alarm: 4CH Active high/low selective input, 1 Relay output
- Various Surveillance Mode included Swing, Tour, Group, Trace and etc.

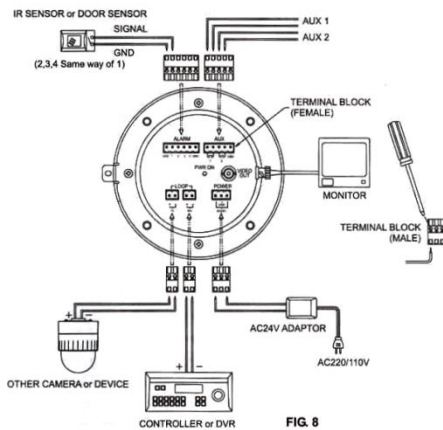

- A-4. Alarm : 4 Alarm input
- A-5. AUX : DC 24V 1A can be used as an AUX terminal.
Turning on the light and remote control are possible using AUX.
- A-6. TX : TX transmits Data signal received from RX to other equipment.
TX is convenient terminal for connection with Daisy Chain.
- A-7. RX : RX are received Control Signal from controller or DVR.
- A-8. Video out : BNC connector
- A-9. Power : AC 24V 1.0A adaptor
- **Don't connect power source to Center terminal of Power.**
- A-10. Power on LED

Technical Document
Technical specification

Model	PTZ 2621		
Pan / Tilt	Pan Rotation Angle		360° Endless
	Pan Speed	Manual	0.5°-100 or 200°/sec (64stop)
		Preset	Max 300° /sec, Min 10° /sec
	Tilt Rotation Angle		-2° - 90°
	Tilt Speed	Manual	0.5° ~ 45°/sec (64stop)
		Preset	Max 250° /sec, Min 200° /sec
System Accuracy		0.024°	
Functions	Presets		165 postions wit 16 character labels available for each postion with different speed stops
	Group Tour		Max 8 programmable group tours (each one consisting of up to 60 preset stops with different steps)
	Auto Pan		Programmable Auto Scan
	Pattern		8 Programmable Patterens (total 480 seconds)
	Sector		8 selectable sectors with 16 characters
	Password Protect		Yes
	Privacy Zones		24
	Alarm Input		4 alarms (with various programmable states)
	Alarm Action		Activate preset, Group scanning or pattern per alarm input
	Alarm Output		2 Replay Outputs
	Auto Flip		ON / OFF
	OSD Menu		Yes
	Communication		RS-485
	Protocal		Built in Pelco-D, Pelco-P
Power	Power Consumption		36W Max
	Power Supply		18~32VAC 60/50Hz 1.5A
Other	Construction		Aluminium body, Anti Vandal Bubble (Poly Carbonate)
	Dimensions		190 (D) * 307mm(H)
	Weight		5.7kg
	Motor Type		Stepping Motor
	Micro Steps		1/8 Micro Step
	Storage Temp		-20. -60. (-4 -140.)
	Operating Temp		-10. -50. (14. -122.) -40. -50.
	Certifications		CE, FCC,IP66
	Image Sensor		1/4" Sony Exview HAD CCD
	Total Image Pixels	NTSC	811(H) * 508(V) 410K
		PAL	795(H) * 596(V) 470K
	Number of Effective	NTSC	768(H) * 494(V) 380K
		PAL	752(H) * 582(V) 440K

Technical Document

Camera Module	Horizonatal resolution		More Than 480TV Lines
	Lens	Optical	26x Optical Zoom (F1.6-3.8, r=3.4 to 91.0mm)
		Digital	12x (312x with Optical)
	Day & Night (ICR)		Auto / Day / Night
	Min Shooting Distance		0.32m(Wide)/1.5m(Tele)
	Digital Slow Shutter		ON / OFF
	Min Illumination	Normal Mode	1.0Lux (50IRE)
		Night Mode	0.01Lux (ICR ON)
	Luminance S/N Ratio		More than 50dB
	Video Output		Composite video output 75 ohm terminated
	BLC		ON / OFF
Flickerless	NTSC	ON / OFF	

Baek Enterprise Ltd.