

 LINEA is an irreversible electromechanical actuator designed with a new conception of gearbox combined with reliable and strong materials. LINEA outstands for its new design and its agreeable lines. It is provided with a practical and handy releasing key that allow a fast and easy emergency manual release in any condition. The female screw is made of bronze to better assure the closing and to last for years. In order to facilitate the installation, there is direct access to the wiring and the capacitor is mounted inside the gearbox. The mechanical stoppers are strong and easy to adjust.

 LINEA es un operador electromecánico irreversible de nueva concepción que une fuerza y fiabilidad con un diseño moderno y líneas agradables. Está hecho por un bastidor en aluminio extrusionado. LINEA tiene un desbloqueo por llave muy simple y muy suave de accionar bajo todas las condiciones. El rodamiento en el sin fin es en bronce para garantizar un cierre en toda seguridad. Los cables de conexión son muy fácil de alcanzar y el condensador se encuentra en el mismo motor. LINEA puede aún montar topes mecánicos muy fácil de añadir y regular.

 LINEA è un attuatore elettromeccanico irreversibile di nuova concezione che abbina doti di robustezza ed affidabilità ad un design moderno e dalle linee piacevoli. Corpo monoscocca in alluminio pressofuso. Sblocco a chiave pratico ed intuitivo che permette la manovra manuale con il minimo sforzo in qualsiasi condizione. Chiocciola in bronzo per una chiusura in tutta sicurezza ed una maggiore durata. Pratico accesso ai collegamenti elettrici e condensatore interno per facilitare il compito dell'installatore. Fermi meccanici pratici e robusti di facile regolazione.

 LINEA est un opérateur électromécanique irréversible de nouvelle conception robuste et fiable avec un design moderne et des lignes agréables. Le moulage est en aluminium sous pression. Le déverrouillage par clé est pratique et simple pour effectuer la manœuvre d'urgence sans efforts et dans toute condition. Coquille en bronze pour une fermeture en toute sécurité et une durée majeure. L'accès aux branchements électriques et au condensateur est pratique pour l'installateur. Les fin de courses mécaniques sont robustes, pratiques et simples à régler.

 tedesco

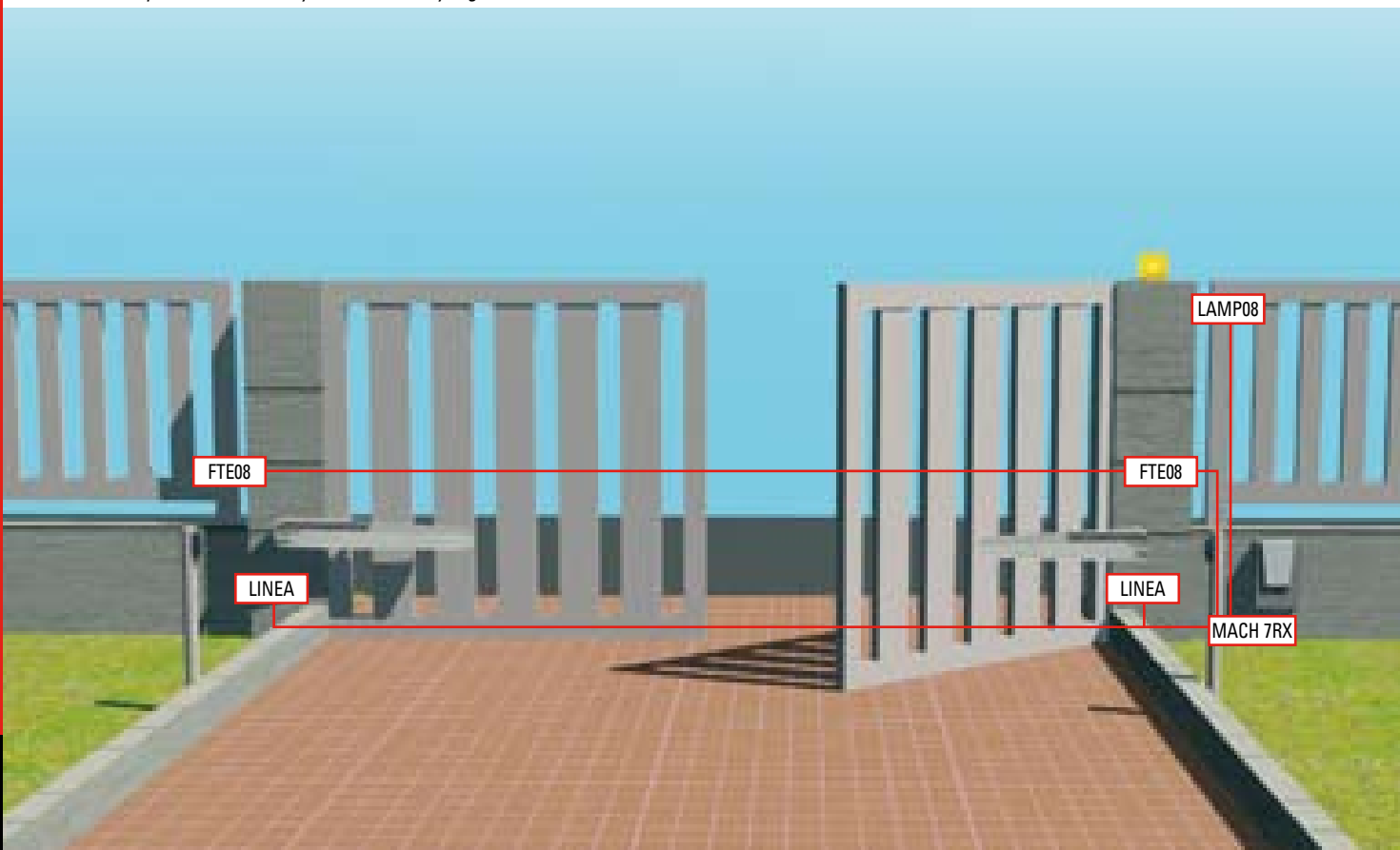

DATI TECNICI	TECHNICAL DATA	LINEA 220	LINEA 24
ALIMENTAZIONE	POWER SUPPLY	230 Vac 50 Hz	24 Vdc
TEMPERATURA DI ESERCIZIO	OPERATING TEMPERATURE	-25° +70° C	-25° +70° C
DIMENSIONE MAX ANTA	MAXIMUM GATE LENGTH	220 CM	220 CM
SPINTA	TORQUE FORCE	1800 N	1600 N
POTENZA	RATED POWER	150 W	70 W
ASSORBIMENTO	ABSORBED POWER	1,3 A	3,0 A
CONDENSATORE	CAPACITOR	8 UF	-
CICLI DI LAVORO	CYCLES PER HOUR	40 %	80 %
CORSA	USABLE STROKE	300 MM	300 MM
GRADO IP	IP	54	54
PESO MOTORE	WEIGHT	12 Kg	12 Kg
TEMPO DI APERTURA	OPENING TIME	17 SEC	15 SEC
LUBRIFICAZIONE	LUBRIFICATION	GRASSO PERMANENTE • PERMANENT GREASING	



- Particolare zona cablaggi.
- Wiring easily reachable.
- Particular de los cables de conexión.
- Vue des branchements électriques.



- Particolare chiave sblocco.
- Manual releasing key.
- Particular de la llave de desbloqueo.
- Clé de déverrouillage.



- Finecorsa meccanici regolabili.
- Adjustable mechanical stoppers.
- Topes mecánicos ajustables.
- Fin de courses mécaniques réglables.

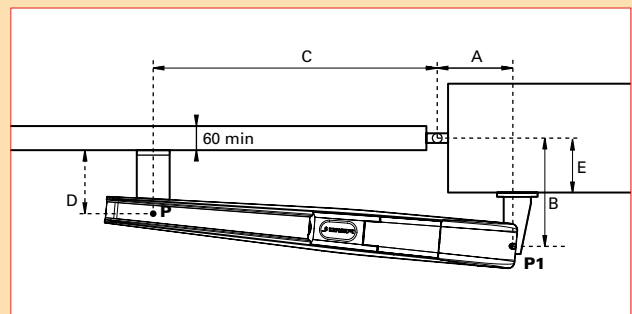
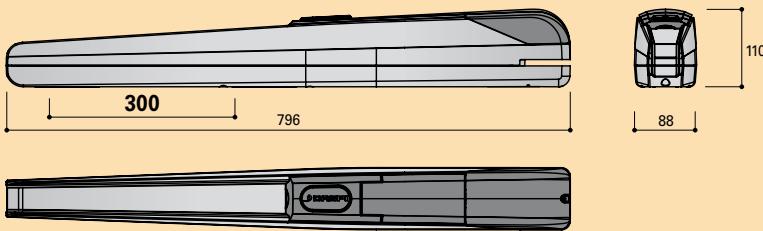

Dimensioni massime dell'anta rispetto al peso dei cancelli azionabili della gamma LINEA.
 Maximum leaf dimensions for LINEA motors.
 Tamaño máximo de la hoja accionable por los motores de la gama LINEA.
 Dimensions maximum du vantail.

MAXIMUM OPENING	A	B	C	D	E	OPENING TIME	LEAF
110°	130	130	550	85	70	12"	1800 MM
90°	130	130	550	85	70	10"	1800 MM
90°	140	140	535	85	90	12"	2000 MM

